

MEASURING SYSTEM "epykon" COLD METER EWZ 637

1. IDENTIFICATION

Manufacturer: Bopp & Reuther Messtechnik GmbH
SBU METRA Energie-Messtechnik
Am Neuen Rheinhafen 4
67346 Speyer / Germany
Phone: +49 6232 657-0
Fax: +49 6232 657-200
E-mail: info@bopp-reuther.com

Product type: Energy measurement / volume transmitter magnetic-inductive cooling meter

Product name: EWZ 637

2. APPLICATION

Measurement and recording of flow and cold quantity of electrically conductive liquids using the magnetic inductive measuring method.



SpiraMAG[®] electromagnetic flow meter
(compact or remote version possible)



Flow computer
ERW 700



Temperature sensor
Pt 1000 / Pt 100

MEASURING SYSTEM "epykon" COLD METER EWZ 637

3. SPECIAL FEATURES

- optionally usable for bidirectional cold measurement
- Very well suited for applications in the water / waste water industry, in the pharmaceutical industry, as well as in the food and beverage industry.
- DN15 to DN1000 (optional DN2000)
- Various connections from DIN to ANSI to JIS
- Very well suited for water / glycol mixtures

4. GENERAL

The EWZ637 consists of the following components:

- SpiraMAG® electromagnetic flow meter with transmitter
- ERW 700 energy calculator with extensive functions
- Temperature sensor Pt 1000 / Pt 100 with immersion sleeve

5. MEASURING POINT DIAGRAM

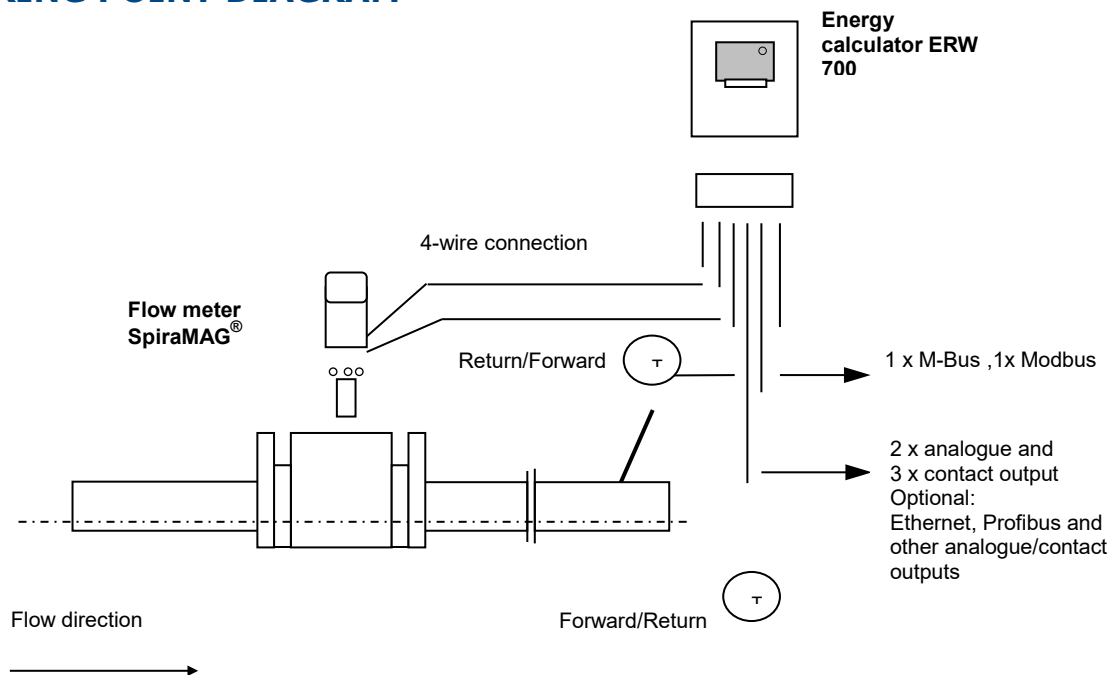

6. MODE OF ACTION AND MEASURING PRINCIPLE

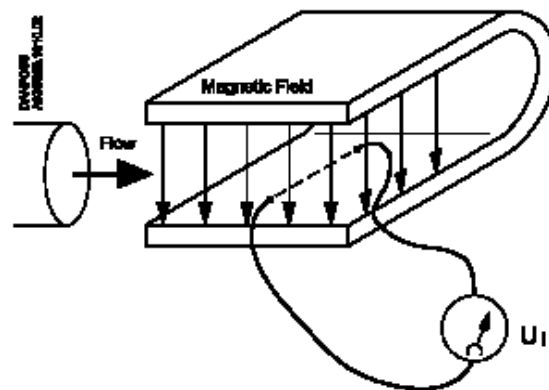

The measuring principle is based on Faraday's law of electromagnetic induction. When an electrical conductor of length L is moved at speed v through a magnetic field of strength B , a voltage U is induced at the ends of the conductor.

$$U_i = L \times B \times v$$

U_i = induced voltage

L = conductor length = inner diameter of the pipeline = k_1

B = magnetic field strength = k_2

v = velocity of the conductor (medium)

$$k = k_1 \times k_2$$

$U_i = k \times v$, the electrode signal is directly proportional to the medium velocity

7. TECHNICAL DATA

SpiraMAG® magnetic inductive volume transmitter

Nominal size	DN	15	25	32	40	50	65	80	100	125	150	200
Qmax.*	[m³/h]	6	9	14	22	35	60	90	140	220	318	560
Qmin.	[m³/h]	0.2	0.5	0.9	1.5	2.1	3.6	5.4	8.5	13	19	34
Nominal pressure stage	PN	40	40	40	40	40	40	40	16	16	16	16
Overall length	[mm]	150	150	150	200	200	200	200	250	250	300	350
Weight	[kg]	6	7	9	11	12	17	17	22	24	35	45

Nominal size	DN	250	300	350	400	450	500	600	700	800	900	1000
Qmax.*	[m³/h]	880	1270	1730	2260	2860	3030	5080	6900	9000	11000	14000
Qmin.	[m³/h]	53	76	104	136	172	212	305	416	543	687	848
Nominal pressure stage	PN	16	16	16	10	10	10	10	10	10	10	10
Overall length	[mm]	400	500	500	600	600	600	600	700	800	900	1000
Weight	[kg]	84	102	123	147	212	229	252	352	462	558	690

* Qmax designed at a flow velocity of 5 m/s. Recommended econom. flow velocity 2-3 m/s

Process temperature	0°C to +70°C (compact or remote mounted, with rubber liner) 0°C to +90°C (remote mounted, with rubber liner) -40°C to +100°C (compactly mounted, with PTFE lining) -40°C to +160°C (remote mounted, with PTFE lining)
Minimum conductivity	≥ 5 µS/cm
Flow rate	0.03 m/s - 10 m/s (recommended 2-3 m/s , see above)
Materials	
Electrode material	Hastelloy C (2.4610), stainless steel platinum plated, Titanium, others on request,
Lining	soft rubber (standard), hard rubber, PTFE / PFA
Measuring tube	Stainless steel SS 316
Housing and flange	Carbon steel, optionally stainless steel

MEASURING SYSTEM "epykon"

COLD METER EWZ 637

SpiraMAG[®] transmitter (for connection to the ERW 700 flow computer)

Measurement uncertainties	Power supplied units: $\pm 0.25\%$ of reading $\pm 0.1\%$ of full scale Battery devices: $\pm 0.5\%$ of the measured value $\pm 0.1\%$ of the final value
Flow direction	directional, optional bidirectional
Ambient temperature	-25°C to +60°C (powered), -10°C to +60°C (battery powered)
Relative humidity	max. 90 %
Power supply	85 265 VAC, (50/60 Hz) / 9-36 VDC / battery
Analogue output	4 - 20 mA
Digital output	Frequency output / pulse (active)
Empty pipe detection	Standard
Communication	Modbus RS 485 or HART [®] protocol (on request)
LCD display	7 digits flow / 8 digits totalizer
Housing	Aluminium
Protection class	IP 67
Remote variant	Standard 10 m, up to 100 m with standard junction box

Energy flow computer ERW 700

Version	Housing for wall/panel mounting
Material housing	ABS (EMC-safe)
Protection class	IP 65 IEC 529/EN 60529 / IP 20 IEC 529/EN 60529 with remote display
Ambient temperature	0 - 55°C
Entrance	2 x analogue 0/4 - 20 mA (active or passive) 2 x frequency / pulse / status
Temperature input	Pt 1000 / Pt 500 / Pt 100 or default value
Supply	230 V, 50 Hz
Display / Count	LCD, alphanumeric for all relevant values
Output potential free	- 2 x (0)4-20mA galvanically isolated, free assignment to all important instantaneous values - 3 x open collector galvanically isolated (optocoupler). Free assignment to the electrical counters, and can be used as a limit contact or status signal. - M-Bus (Meter Bus) galvanically isolated - Hardware: RS 232 (Modbus RTU, Modbus ASCII)
Connecting cable	Standard 5 m, max. up to 200 m
Auxiliary energy	230VAC or 24VDC

MEASURING SYSTEM "epykon"

COLD METER EWZ 637

Additional equipment Energy flow computer ERW 700

Output: Expansion stage 1 (basic unit plus 1 additional output card) - 4 x (0)4 - 20 mA galvanically isolated, - 5 x pulse/status, galvanically isolated (optocoupler) - 1 x M-Bus - 1 x RS 232 Modbus
Output: Expansion stage 2 (basic unit plus 2 additional output cards) - 6 x (0)4 - 20 mA galvanically isolated - 7 x pulse/status, galvanically isolated (optocoupler) - 1 x M-Bus - 1 x RS 232 Modbus
Output: Expansion stage with special outputs (basic unit plus additional output card incl. outputs up to expansion stage2) - 2. M-Bus interface or - Ethernet interface with Modbus TCP/IP protocol - RS-485 interface Additionally with Profibus DP module
Input: Expansion stage 1 (basic unit plus 1 additional input card): - 4 x (0)4 - 20 mA, - 2 x pulse / frequency - 4 x transmitter supply
Special calibration for water-glycol mixtures, other liquid mixtures with constant mixing ratio
Density input (0)4 - 20 mA in combination with density transmitter (for changing mixing ratios)
ERW 700 version in 19" rack
Special version with additional counter (e.g. bidirectional measurement, limit-dependent tariff switching)
System testing, commissioning and instruction by METRA Customer Service

8. INSTALLATION INSTRUCTIONS

Alignment of the measuring device

The measuring device can be installed in both horizontal and vertical pipelines. The housing of the transmitter can be rotated by 90° / 180°.

Inlet and outlet section

The meter should not be installed downstream of fittings that generate turbulence. If this is not possible, a straight inlet section greater than 5 x DN and an outlet section greater than 3 x DN should be provided.

**MEASURING SYSTEM "epykon"
COLD METER EWZ 637**

Positioning of the measuring device

The following installation instructions must be observed to avoid turbulence or the accumulation of gas bubbles, which can affect the flow accuracy.

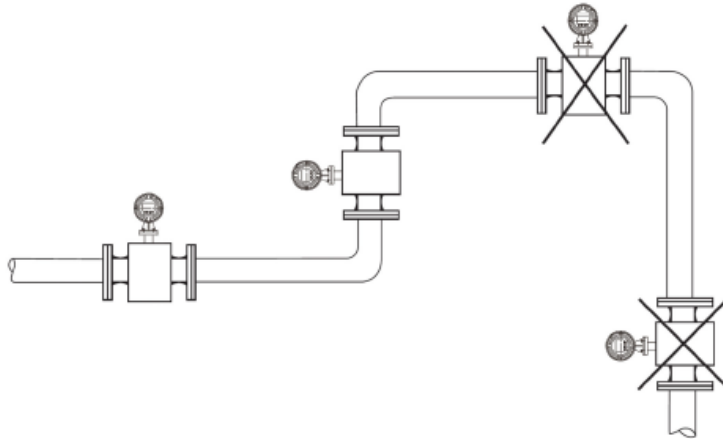

Avoid installing the meter at the highest point of the piping system. This prevents the accumulation of gas bubbles, which leads to measurement errors. Likewise, avoid installation in downward-flowing pipes (a partially filled pipe is easily formed).

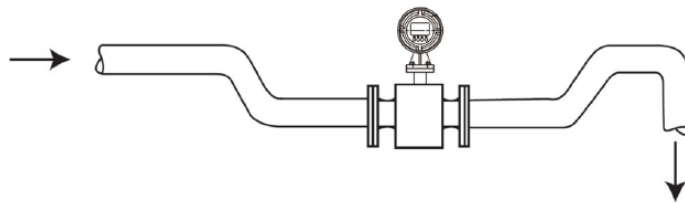

For downpipes, the unit should be installed in a lower position according to the illustration.

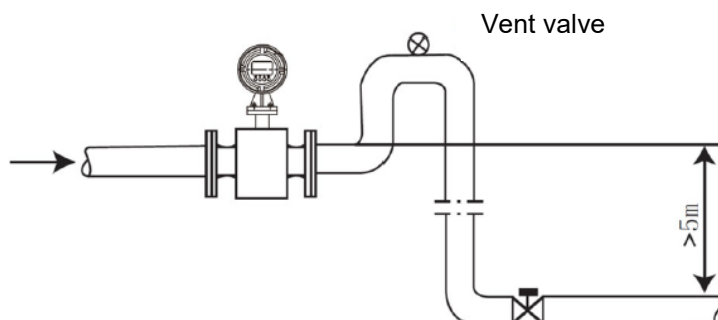

A vent valve should be sent if the downpipe is longer than 5m.

MEASURING SYSTEM "epykon"
COLD METER EWZ 637

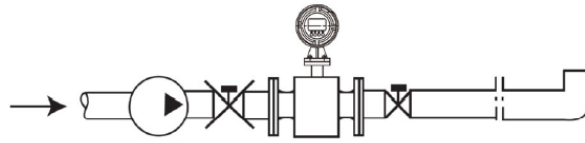

In longer pipe systems, control and shut-off valves must be installed on the downstream side of the meter.

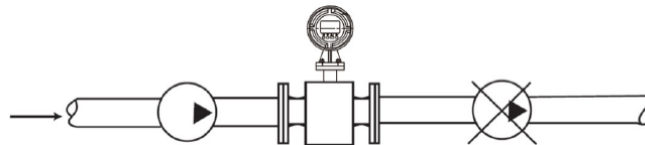

The meter should not be installed on the suction side of the pump.

9. DIMENSIONS

SpiraMAG® electromagnetic flowmeter

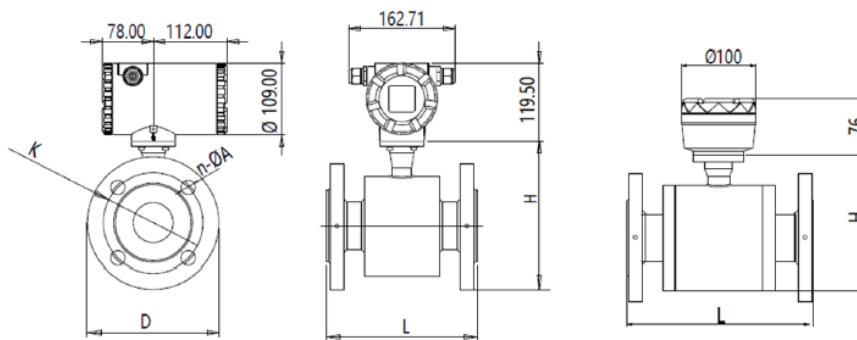

MEASURING SYSTEM "epykon"
COLD METER EWZ 637

Nominal size DN	15	25	32	40	50	65	80	100	125	150	200
Pressure stage PN	40	40	40	40	40	40	40	16	16	16	16
L [mm]	150	150	150	200	200	200	200	250	250	300	350
D [mm]	95	115	140	150	165	185	200	220	250	285	340

Nominal size DN	250	300	350	400	450	500	600	700	800	900	1000
Pressure stage PN	16	16	16	10	10	10	10	10	10	10	10
L [mm]	400	500	500	600	600	600	600	700	800	900	1000
D [mm]	395	445	505	565	615	670	780	895	1015	1115	1235

Flow computer

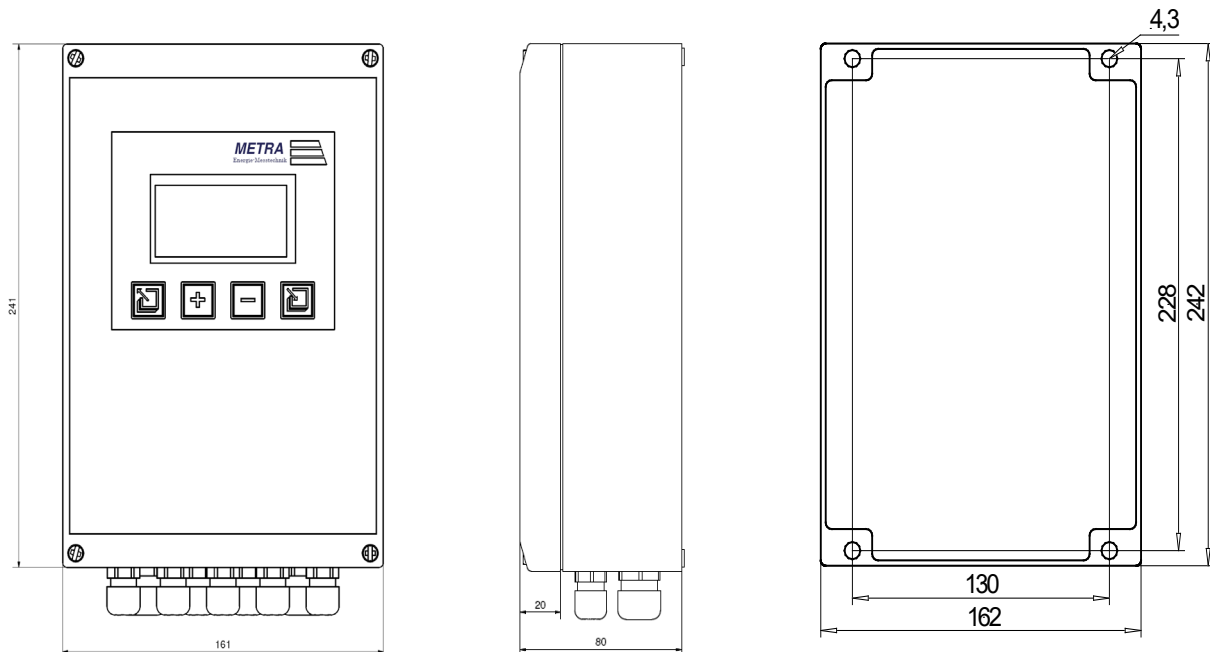

MEASURING SYSTEM "epykon" COLD METER EWZ 637

Temperature sensor with immersion sleeve

Connection head	Form J, die-cast aluminium
Cable gland	M16 x 1.5
Ambient temperature	-20 to 100°C
Protective tube	Stainless steel 1.4571 7.8 mm with fitting tolerance for protective sleeves
Measuring insert	Platinum temperature sensor according to DIN EN 60751
Nominal value, class	PT1000, class AA PT100, class A
Connection	Two- or four-wire circuit, shielded or unshielded
Medium temperature	PT1000: -50 to +200°C PT100: -50 to +400°C
Operating pressure	25 bar without protective sleeve 40 bar with standard protective sleeve
Minimum immersion depth	30 mm
Installation length (EL)	95 to 400 mm
Response time	$t_{0,5} < 8 \text{ s}$ $t_{0,5} < 22 \text{ s}$ (installed in protective sleeve)
Environmental conditions	climatic 0 to +70°C Protection class IP65 Electromagnetic E1 mechanical M3 Environment class C
Accessories	Protective sleeves

MEASURING SYSTEM "epykon" COLD METER EWZ 637

Temperature sensor with immersion sleeve

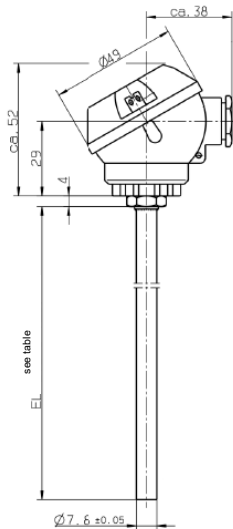

Resistance thermometer	
EL	130 mm 250 mm 300 mm other lengths on request

Standard protective sleeve	
EL	75 mm 160 mm 200 mm other lengths on request

Standard protective sleeve

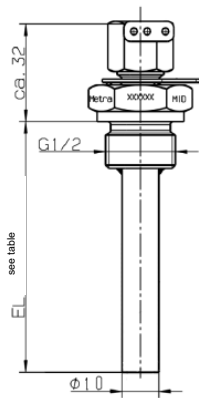

Weld-in protective sleeve

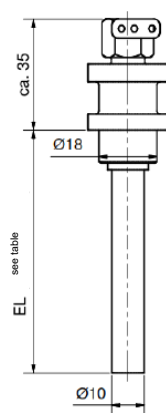

Weld-in protective sleeve (without type approval)

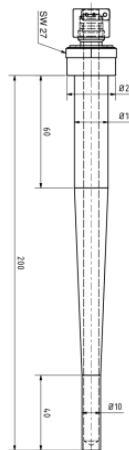

MEASURING SYSTEM "epykon" COLD METER EWZ 637

10. ORDER AND TENDER TEXT

Cold meter "epykon"® EWZ 637

consisting of:

Flow meter SpiraMAG®

Medium, DN, PN

Nominal flow rate m/h³, t/h,

Operating temperature °C, operating pressure bar (abs.),

Mounting position horizontal / vertical

Protection class IP 67, minimum conductivity 5 µS,

3-point measurement protocol on accredited test bench (water basis)

Calculator ERW 700 Flow and cold calculator

Suitable for wall and panel mounting

Outputs: 2 x (0) 4-20 mA galvanically isolated, free assignment to all important instantaneous values

2 x open collector galvanically isolated (optocoupler). Free assignment to the electrical counters and can be used as a limit contact or status signal.

M-Bus (Meter Bus) galvanically isolated

Hardware: RS 232 (Modbus RTU, Modbus ASCII)

Multifunction graphic display for Q, P, tw, tk, Δt

Protection class IP 65

Power supply 230 VAC

2 Pt 1000 temperature sensors including immersion sleeve type 75/160/200

Additional equipment

Output: Expansion stage 1 (basic unit plus 1 additional output card) - 4 x (0)4 - 20 mA galvanically isolated, - 5 x pulse/status, galvanically isolated (optocoupler) - 1 x M-Bus - 1 x RS 232 Modbus
Output: Expansion stage 2 (basic unit plus 2 additional output cards) - 6 x (0)4 - 20 mA galvanically isolated - 7 x pulse/status, galvanically isolated (optocoupler) - 1 x M-Bus - 1 x RS 232 Modbus
Output: Expansion stage with special outputs (basic unit plus additional output card incl. outputs up to expansion stage2) - 2. M-Bus interface or - Ethernet interface with Modbus TCP/IP protocol - RS-485 interface additionally with Profibus DP module
Input: Expansion stage 1 (basic unit plus 1 additional input card): - 4 x (0)4 - 20 mA, - 2 x pulse/frequency - 4x transmitter supply
Density input (0)4 - 20 mA in combination with density transmitter (for changing mixing ratios)
ERW 700 version in 19" rack
Special calibration for water-glycol mixtures, other liquid mixtures with constant mixing ratio
Special version with additional counter (e.g. bidirectional measurement, limit-dependent tariff switching)
System testing, commissioning and instruction by METRA customer service